

Super Bass Extreme | Floor

Page 1 of 1 |

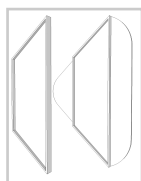
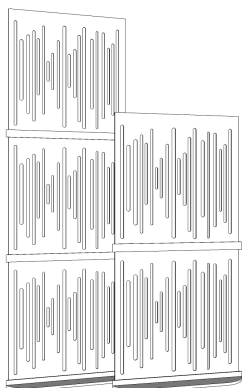

Required Apparatus:

- 3 x Super Bass Extreme (Panel)
- 2 x Stacker Base
- 1 x Stacker Level
- 20 x self-adhesive Rubber Feet

Installation Instructions:

Make sure the room has all the necessary conditions to receive the acoustic panels.
These installation instructions mention the contents and installation process to stack three Super Bass Extreme panels.

STEP 1

Stick 4 (four) Rubber Feet the top side of the Stacker Base as shown in the image.

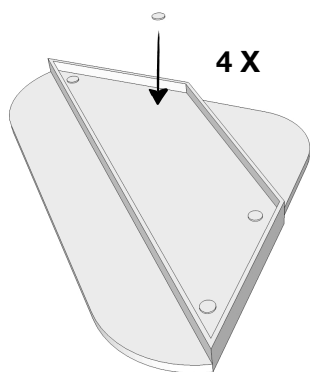

STEP 2

Insert the Super Bass Extreme Panel in the Stacker Base.

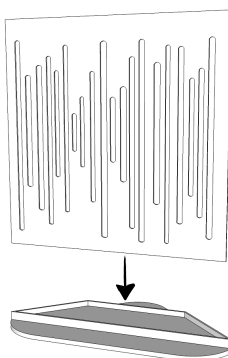

STEP 3

Stick 4 (four) Rubber Feet on both sides of the 1st Stacker Level, as shown in image above.

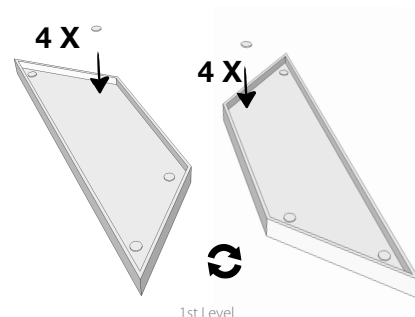

STEP 4

Assemble the 1st Stacker Level to the Super Bass Extreme Panel and insert the 2nd Super Bass Extreme Panel on top of the structure.

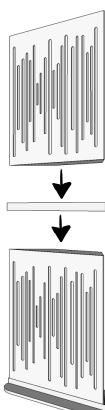

STEP 5

Stick 4 (four) Rubber Feet on both sides of the 2nd Stacker Level, as shown in image above.

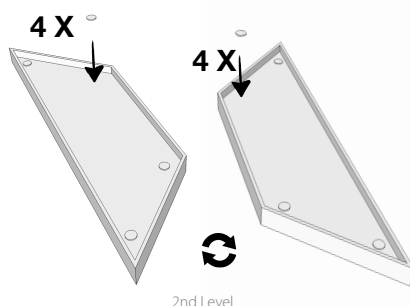

STEP 6

Assemble the 2nd Stacker Level to the Super Bass Extreme Panel and insert the 3rd Super Bass Extreme Panel on top of the structure.

